

Electrolux air-o-steam - level B

Combi LW 10 GN 1/1-electric

Electrolux air-o-steam blends tradition with the latest technological research in order to satisfy the creativity and working requirements of today's professional kitchen. The air-o-steam range offers a choice of different models available in two levels of operation, providing a high degree of automation and an extensive range of accessories. The air-o-steam combis are designed to form complete cook&chill systems together with air-o-chill blast chillers/freezers, therefore, any installation can be tailored to meet the needs of the caterer. The air-o-steam combis detailed are level B, 10 GN 1/1 electric models.



268202

OPERATING MODES

- Convection cycle (max. 300 °C): ideal for meat to be cooked without humidity and "au gratin". In conjunction with the half-power function for all kinds of pastry cooking.
- Steam cycle (max. 130 °C): for products that can be cooked in water. Steam cooking respects the original properties of food and reduces weight loss.
- Combi cycle (max. 250°C): ideal for most kinds of cooking. Impressive reduction of cooking times and food shrinkage. The humidity generated by the food and the steam generator is automatically controlled by the By-pass technology for saving water and energy.

- air-o-steam ovens can cook by controlling either the cooking time or the product's core temperature through a single-sensor probe.
- Regeneration cycle: it produces the best humidity conditions for quickly heating the products to be regenerated (max. 250°C) on the plate.
- Exhaust valve electronically controlled to extract the humidity excess.
- Fan speeds: full, half speed (for delicate cooking such as for baking cakes) and PULSE (pulse ventilation for baking and low temperature cooking). The "PULSE function" is also perfect for keeping food warm at the end of the cooking cycle.
- Low power cycle: for delicate cooking such as for baking cakes.

- Eco-delta: the temperature inside the cooking cell is higher than the temperature of the food and rises accordingly.
- Air-o-clean: 4 different pre-set cycles to clean the cooking cell, according to the actual requirements. The cleaning system is built-in (no need for add-ons). Semi-automatic cleaning cycle also available.
- Quick cooling: useful when passing to a type of cooking that requires a lower temperature than the previous one, works both automatically and manually.
- Manual injection of water in the cell.
- Automatic steam generator water draining with an automatic scale diagnosis system.



Electrolux

**Electrolux air-o-steam - level B
Combi LW 10 GN 1/1-electric**

PERFORMANCE

- By-pass technology: controls the humidity degree of the oven atmosphere in combi and regeneration cycles. It prevents water and energy waste.

- air-o-flow: blows fresh air from outside through the bi-functional fan, which pulls the air in from the backside of the oven after it is pre-heated, thus guaranteeing an even cooking process.
- Single-sensor food probe.

CONSTRUCTION

- Stainless steel 304 throughout, with seamless joints in the cooking cell.
- Double thermo-glazed door equipped with drip pans to catch condensate and prevent slippery floor for maximum security and four holding positions allowing easier loading and unloading.

- Halogen lighting in the cooking cell.
- Access to main components from the front panel.
- Automatic scale diagnosis system in the steam generator to detect the presence of scale build-up.
- IPX5 water protection.
- air-o-steam ovens meet IMQ safety requirements.

TECHNICAL DATA	AOS101EBA2 268202	AOS101EBH2 268212	AOS101EBN2 268222
Power supply	Electric	Electric	Electric
Number of grids	10	8	10
Runners pitch - mm	65	80	65
Cooking cycles - °C			
air-convection	300	300	300
steam	130	130	130
combi	250	250	250
Convection	●	●	●
Steaming	●	●	●
Convection/steaming	●	●	●
Regeneration	●	●	●
Low temp steaming	●	●	●
Two-speed fan	●	●	●
Meat probe	●	●	●
Automatic cleaning system	●	●	●
External dimensions - mm			
width	898	898	898
depth	915	915	915
height	1058	1058	1058
Internal dimensions - mm			
width	460	460	460
depth	715	715	715
height	736	736	736
Power - kW			
boiler	17	17	17
auxiliary	0.5	0.5	0.5
cooking chamber	17	17	17
electric	17.5	17.5	17.5
auxiliary	0.5	0.5	0.5
Net weight - kg.	156	156	156
Supply voltage	400 V, 3N, 50/60	400 V, 3N, 50/60	230 V, 3, 50/60

**Electrolux air-o-steam - level B
Combi LW 10 GN 1/1-electric**

	AOS101EBA2 268202	AOS101EBH2 268212	AOS101EBN2 268222
ACCESSORIES			
1 GRID GN1/1 FOR 8 WHOLE CHICKENS(1.2KG)	922266	922266	922266
1 GRID GN1/2 FOR 4 WHOLE CHICKENS(1.2KG)	922086	922086	922086
2 FRYING BASKETS FOR OVENS	922239	922239	922239
2 GRIDS GN 1/1 FOR CHICKENS (8 PER GRID)	922036	922036	922036
AUTOMATIC WATER SOFTENER FOR OVENS	921305	921305	921305
BAKING TRAY FOR BAGUETTE GN 1/1	922288	922288	922288
BAKING TRAY(400X600X20)4 EDGES-ALUMINIUM	922191	922191	922191
BAKING TRAY(400X600X20)4 EDGES-PERF.ALUM	922190	922190	922190
BANQUET RACK-23PLATES-85MM PITCH-10GN1/1	922071	922071	922071
BANQUET RACK-30PLATES-65MM PITCH-10GN1/1	922015	922015	922015
BASKET FOR DETERGENT TANK-WALL MOUNTED	922209	922209	922209
CONTROL PANEL FILTER-6&10 GN1/1 OVENS-LW	922246	922246	922246
CUPB. BASE+TRAY SUPP-6&10 GN1/1 OVENS LW	922096	922096	922096
DOUBLE-CLICK CLOSING CATCH FOR OVEN DOOR	922265	922265	922265
DRAIN KIT (D=50MM) OVENS 6&10 GN 1/1-2/1	922283	922283	922283
EGG FRYER FOR 8 EGGS - GN 1/1	922290	922290	922290
EXHAUST HOOD WITH FAN FOR 6&10 GN1/1-LW	640792	640792	640792
EXHAUST HOOD WITHOUT FAN F. 6&10GN1/1-LW	640791	640791	640791
EXTERNAL CONN. KIT FOR DETERG./RINSE AID	922169	922169	922169
EXTERNAL SIDE SPRAY UNIT	922171	922171	922171
FAT FILTER FOR OVENS 10X1/1-2/1	922178	922178	922178
FRYING GRIDDLE GN 1/1 FOR OVENS	922215	922215	922215
FRYING GRIDDLE GN 2/3 FOR OVENS	922284	922284	922284
GREASE COLLECTION KIT (TRAY+TROLLEY)	922287	922287	922287
HEAT SHIELD FOR 10 GN 1/1 OVENS	922251	922251	922251
HEAT SHIELD FOR STACKED OVEN 6GN ON 10GN	922245	922245	922245
HOLDER FOR DETERGENT TANK ON OPEN BASE	922212	922212	922212
HOT CUPB.+TRAY SUPP-6&10 GN1/1+(400X600)	922224	922224	922224
KIT 4 ADJUSTABLE FEET	922012	922012	922012
KIT HACCP EKIS	922166	922166	922166
KIT INTEGRATED HACCP FOR OVENS	922275	922275	922275
NON-STICK U-PAN GN 1/1 H=20 MM	922090	922090	922090
NON-STICK U-PAN GN 1/1 H=40 MM	922091	922091	922091
NON-STICK U-PAN GN 1/1 H=65 MM	922092	922092	922092
NON-STICK U-PAN GN 2/3 H=20 MM	922285	922285	922285
ODOURLESS HOOD+FAN-6&10GN1/1 ELLW	640796	640796	640796
OPEN BASE+TRAY SUPPORT 6&10X1/1GN LW	922195	922195	922195
OVEN GRILL (ALUMINIUM) GN 1/1	922289	922289	922289
PAIR OF 1/1GN AISI 304 S/S GRIDS	922017	922017	922017
PASTRY 8X(400X600)RACK+WHLs-80MM,10X1/1	922066	922066	922066
PASTRY RUNNERS (400X600) 6&10GN1/1 BASES	922286	922286	922286
RESIN SANITIZER FOR WATER SOFTENER	921306	921306	921306
SLIDE-IN RACK+HANDLE FOR 6&10 GN1/1-LW	922074	922074	922074
STACKING KIT- EL. 6X1/1 ON EL. 6&10X1/1	922217	922217	922217
THERMAL COVER FOR 10X1/1GN-LW	922013	922013	922013
TRAY RACK+REINF.10X1/1GN, 64MM PITCH-LW	922099	922099	922099
TRAY RACK+WHEELS 10X1/1GN, 65MM PITCH	922006	922006	922006
TRAY RACK+WHEELS 8X1/1GN, 80MM PITCH	922009	922009	922009
TRAY SUPPORT FOR 6&10 GN1/1 OVEN BASES	922021	922021	922021
TRAY(400X600X38)5 ROWS-PERF.ALUM/SILICON	922189	922189	922189
TROLLEY FOR SLIDE-IN RACK 6&10X1/1GN	922004	922004	922004
WATER FILTER FOR OVENS 0.8 L/MIN.	922186	922186	922186
WHEEL KIT FOR BASE OF 6&10X1/1 LW	922003	922003	922003

ECAB020

2011-02-22

Subject to change without notice

**Electrolux air-o-steam - level B
Combi LW 10 GN 1/1-electric**

268202, 268222, 268212

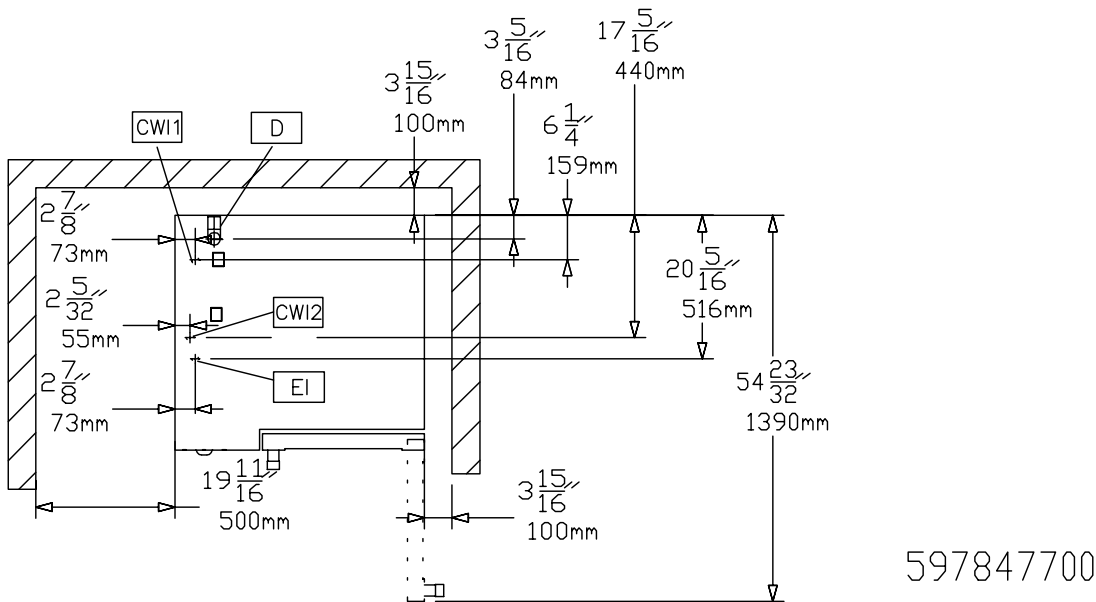
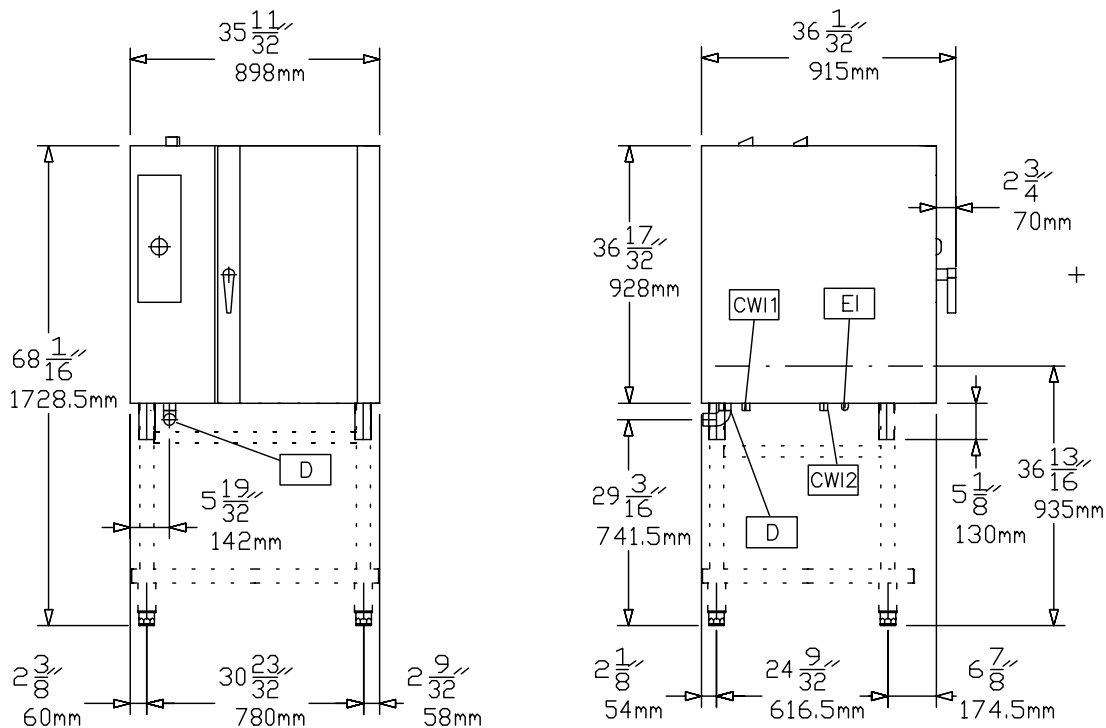

ECAB020

2011-02-22

LEGEND	AOS101EBA2 268202	AOS101EBH2 268212	AOS101EBN2 268222
	CWI - Cold water inlet	3/4"	3/4"
D - Water drain	1"1/4	1"1/4	1"1/4
EI - Electrical connection	400 V, 3N, 50/60	400 V, 3N, 50/60	230 V, 3, 50/60
WIC - Cooling water inlet	3/4"	3/4"	3/4"

Subject to change without notice